

parallel Thread

$$H = 0.960491 \times p$$

$$h = 0.610327 \times p$$

$$H = 0.137329 \times p$$

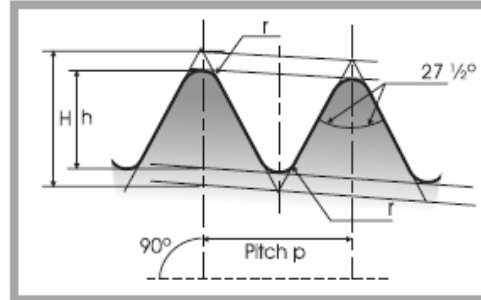

Taper Thread (Taper 1 in 16 on dia.)

$$H = 0.960237 \times p \text{ (Shown exaggerated)}$$

$$H = 0.610327 \times p \text{ in diagram}$$

$$H = 0.137278 \times p \text{ Axis of screw}$$

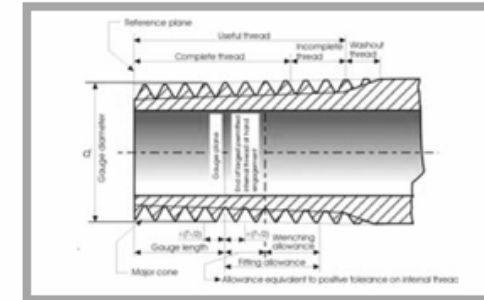

Dimensions in mm.

Thread size designation (inches)	Number of threads in 25.4 mm.	Pitch P	Depth of thread h	Basic diameters at gauge plane			Gauge length				Basic gauge length
				Major d	Pitch d2	Minor d1	Basic	Tolerance T1/2	Maximum	Minimum	
1/8	28	0.907	0.581	9.728	9.147	8.566	4.0	0.9	4.9	3.1	6.5
1/4	19	1.337	0.856	13.157	12.301	11.445	6.0	1.3	7.3	4.7	9.7
3/8	19	1.337	0.856	16.662	15.806	14.950	6.4	1.3	7.7	5.1	10.1
1/2	14	1.814	1.162	20.955	19.793	18.631	8.2	1.8	10.0	6.4	13.2
3/4	14	1.814	1.162	26.441	25.279	24.117	9.5	1.8	10.0	7.7	14.5
1	11	2.309	1.479	33.249	31.770	30.291	10.4	2.3	12.7	8.1	16.8
1 1/4	11	2.309	1.479	41.910	40.431	38.952	12.7	2.3	15.0	10.4	19.1
1 1/2	11	2.309	1.479	47.803	46.324	44.845	12.7	2.3	15.0	10.4	19.1
2	11	2.309	1.479	59.614	58.135	56.656	15.9	2.3	18.2	13.6	23.
2 1/2	11	2.309	1.479	75.184	73.705	72.226	17.5	3.5	21.0	14.0	26.7
3	11	2.309	1.479	87.884	86.405	84.926	20.6	3.5	24.1	17.1	29.8
4	11	2.309	1.479	113.030	111.551	110.072	25.4	3.5	28.9	21.9	35.8
5	11	2.309	1.479	138.430	136.951	135.472	28.6	3.5	32.1	25.1	40.1
6	11	2.309	1.479	163.830	162.351	160.872	28.6	3.5	32.1	25.1	40.1